

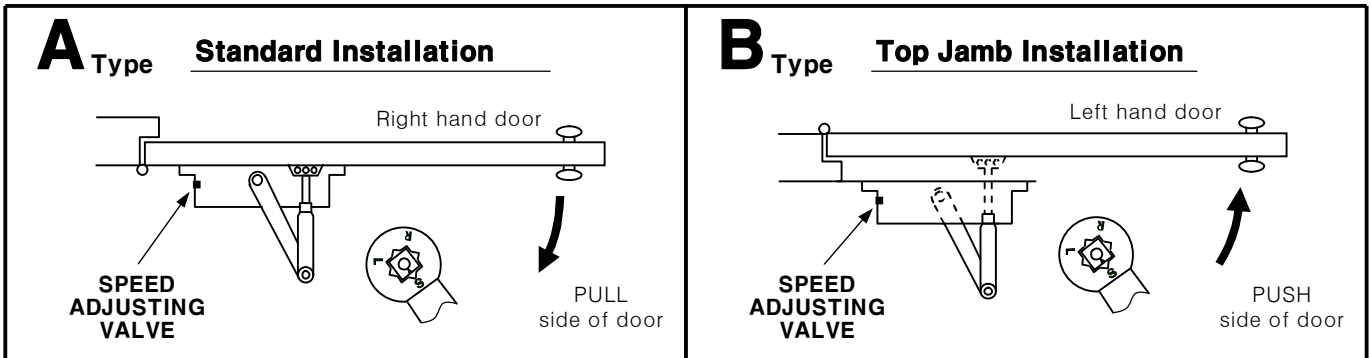

SENTINEL

Installation Instructions

Series 5000



Please note

This drawing is not to full scale. Therefore, do not use it as your template to locate the hole positions while you fabricate your door and frame for the installation of this product. Instead, make the measurements needed manually without the use of the enclosed template which is not to full scale.

A Type STANDARD (PULL SIDE) Mounting

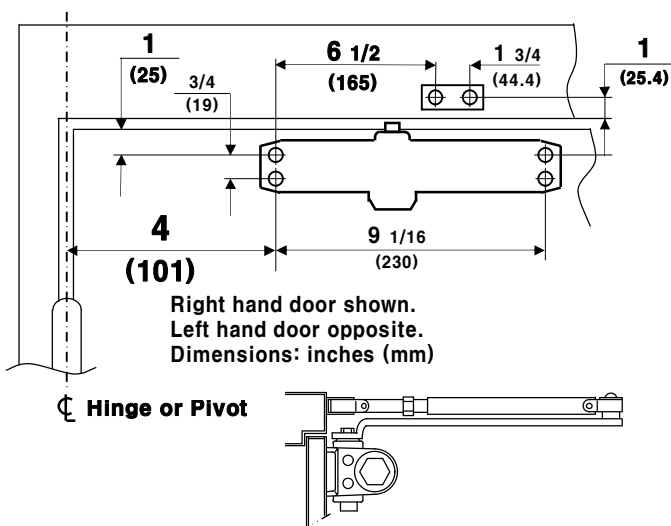

INSTALLATION INSTRUCTIONS

- Using template dimensions shown above, mark FORE(4) HOLES ON DOOR for door closer and TWO(2) HOLES ON FRAME for arm shoe.
- Drill pilot holes in door and frame for #14 all-purpose screws or drill and tap for 1/4-20 machine screws.
- Install adjustable forearm/arm shoe to frame using screws provided.
- Mount closer on door using screws provided. **SPEED ADJUSTING VALVE MUST BE POSITIONED TOWARD HINGE EDGE.**
- Install main arm to top pinion shaft, perpendicular to door as shown below. Secure tightly with arm screw/washer assembly provided.
- Adjust length of forearm so that forearm is perpendicular to frame when assembled to preloaded main arm (Illustration below). Secure forearm to main arm with screw/washer assembly provided.
- Adjust closing speed of door,
- Snap pinion cap over shaft at bottom of closer.

B Type TOP JAMB (PUSH SIDE) Mounting

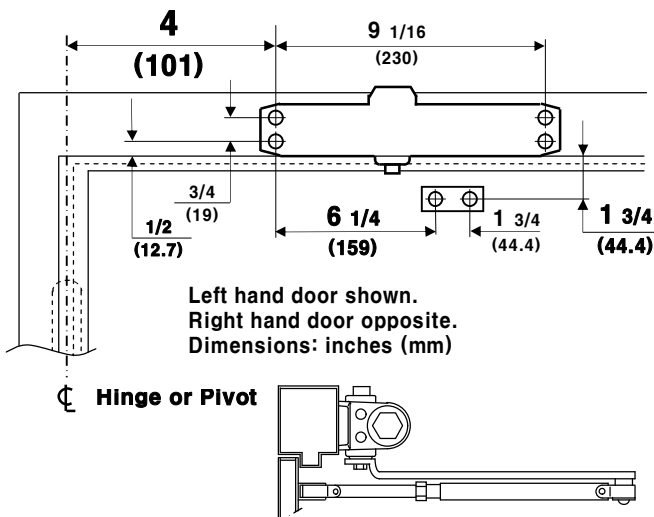

INSTALLATION INSTRUCTIONS

- Using template dimensions shown above, mark FORE(4) HOLES ON FRAME for door closer and TWO(2) HOLES ON DOOR for arm shoe.
- Drill pilot holes in door and frame for #14 all-purpose screws or drill and tap for 1/4-20 machine screws.
- Install adjustable forearm/arm shoe to door using screws provided.
- Mount closer on frame using screws provided. **SPEED ADJUSTING VALVE MUST BE POSITIONED TOWARD HINGE EDGE.**
- Install main arm to top pinion shaft, perpendicular to door as shown below. Secure tightly with arm screw/washer assembly provided.
- Adjust length of forearm so that forearm is perpendicular to door when assembled to preloaded main arm (Illustration below). Secure forearm to main arm with screw/washer assembly provided.
- Adjust closing speed of door, Snap pinion cap over shaft at bottom of closer.

Installation Instructions

Series 5000

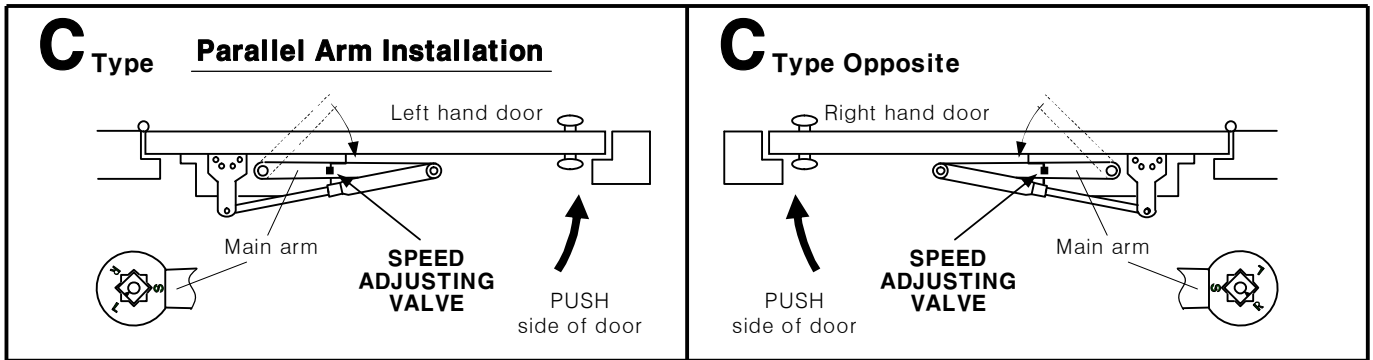

Please note

This drawing is not to full scale. Therefore, do not use it as your template to locate the hole positions while you fabricate your door and frame for the installation of this product. Instead, make the measurements needed manually without the use of the enclosed template which is not to full scale.

C Type PARALLEL ARM (PUSH SIDE) Mounting

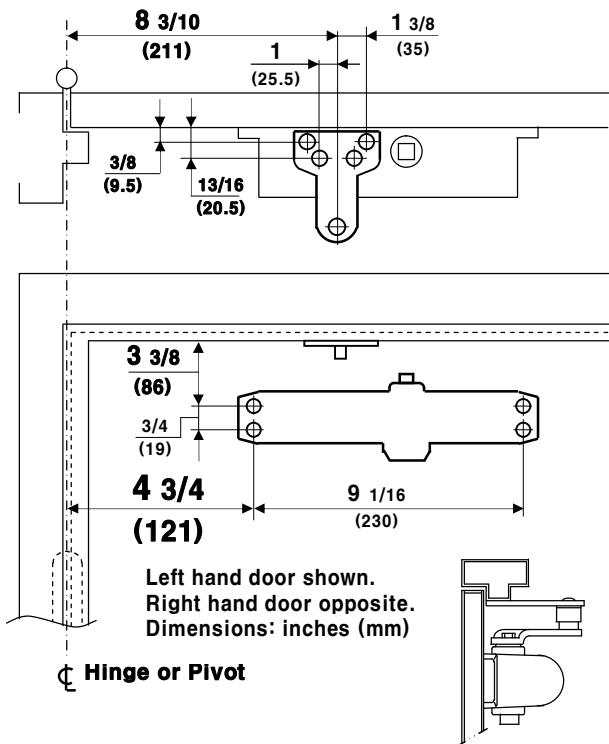

INSTALLATION INSTRUCTIONS

- Using template dimensions shown above, mark FORE (4) HOLES ON DOOR for door closer and FORE (4) HOLES ON FRAME for parallel bracket.
- Drill pilot holes in door and frame for #14 all-purpose screws or drill and tap for 1/4-20 machine screws.
- Install Parallel Arm Bracket shoe to frame using screws provided.
- Mount closer on door using screws provided. **SPEED ADJUSTING VALVE MUST BE POSITIONED TOWARD AWAY FROM HINGE EDGE.**
- Install main arm to top pinion shaft, with arm pointing toward speed adjusting screw. Secure tightly with arm screw/washer assembly provided.
- Remove arm shoe from fore arm and discard. Install ROD end of fore arm to bracket using screw/washer assembly provided. Adjust length of fore arm to set arm elbow approximately 1-1/2" (38mm) from door (refer to illustration below). Attach forearm to main arm by rotating main arm away from door. Secure forearm to main arm using screw/washer assembly provided.
- Adjust length of fore arm so when it is attached to main arm the main arm will be slightly away from parallel with closed door and assemble at elbow then tighten locknut.
- Adjust door closing speed by speed adjusting valves.
- Snap pinion cap over shaft at bottom of closer.

CLOSER ADJUSTMENT

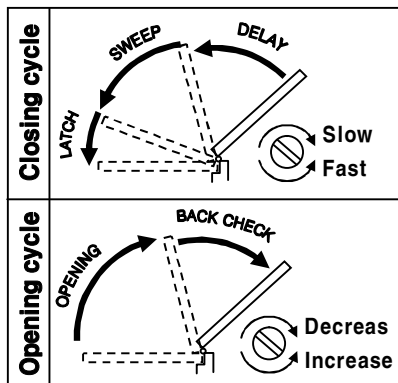
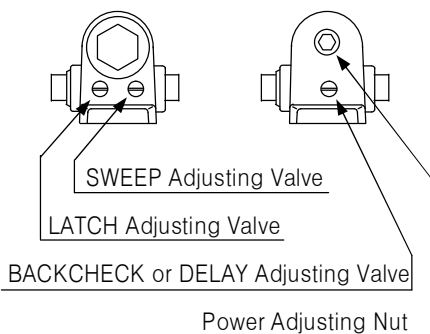

POWER ADJUSTMENT CHART		
CLOSER SIZE	CLOCKWISE TURNS OF ADJUSTING NUT	
	5000	5000BF
1	-	-8
2	-4	-3
3	0	0
4	6	6
5	12	-