

Installation Instructions - Pocket Door Mortise Lock

See included template for door prep specifications

Drill two 1/8" pilot holes
7-1/8" apart on center.

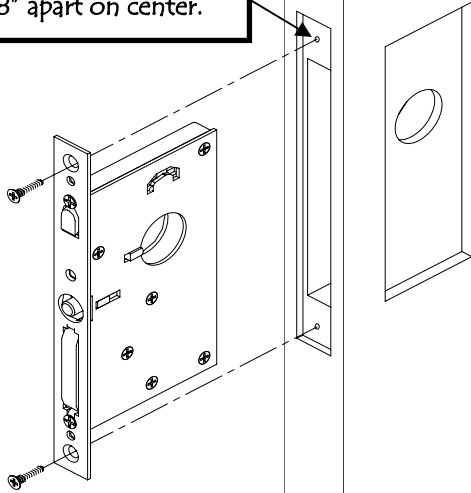

Install lock body into door.

Inside Trim

Thread Drive Bar Cylinder into lock body.
NOTE: Drive Bar Socket must be in the
12 o'clock position as shown.

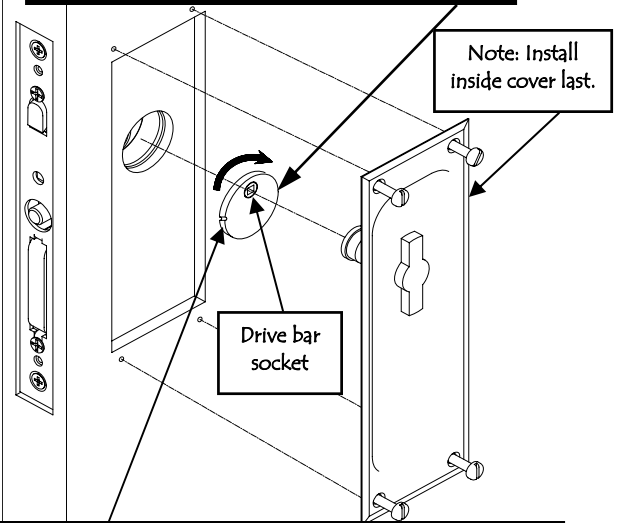

Note: Notch on cylinder must be in the 9 o'clock position when fully screwed into lock body.

Outside Trim

Note: Key Cylinder notch must be at the
3 o'clock position when fully screwed in lock body.

Note: Outside cover must
be installed before cylinder.

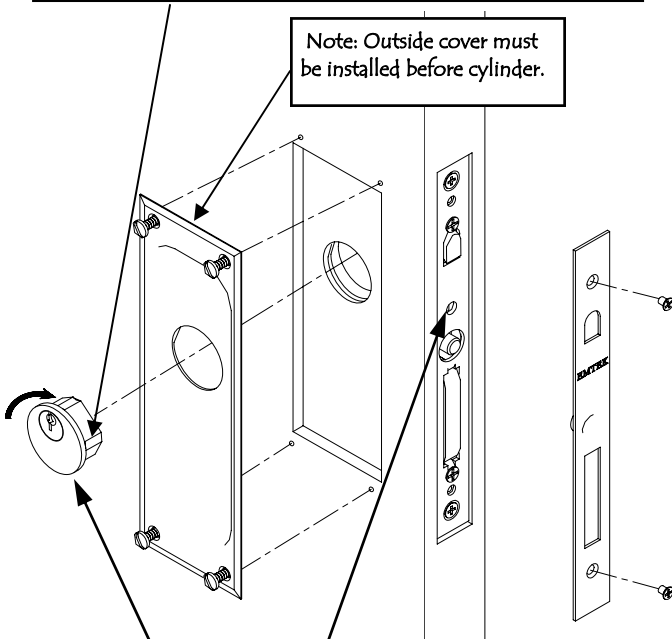

After threading both inside & outside cylinders into
lock body, tighten locking screw counter clockwise
to engage notches on both cylinders.
NOTE: DO NOT OVER TIGHTEN SCREW.

Door Jamb Prep.

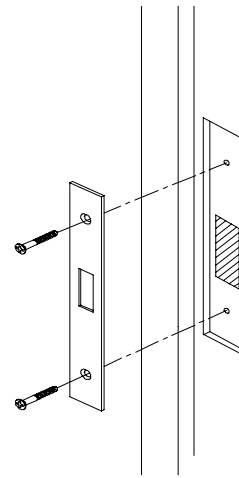

Drill two 1/8" pilot holes for wood screws provided).

EMTEK
ASSA ABLOY